

L:

CBL-HFD3SAB6CSS-6m	6000mm±30mm
CBL-HFD3SAB6CSS-7m	7000mm±30mm
CBL-HFD3SAB6CSS-8m	8000mm±30mm
CBL-HFD3SAB6CSS-9m	9000mm±30mm
CBL-HFD3SAB6CSS-10m	10000mm±30mm

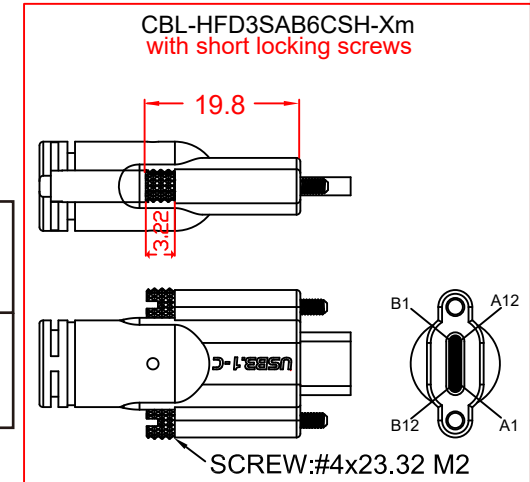
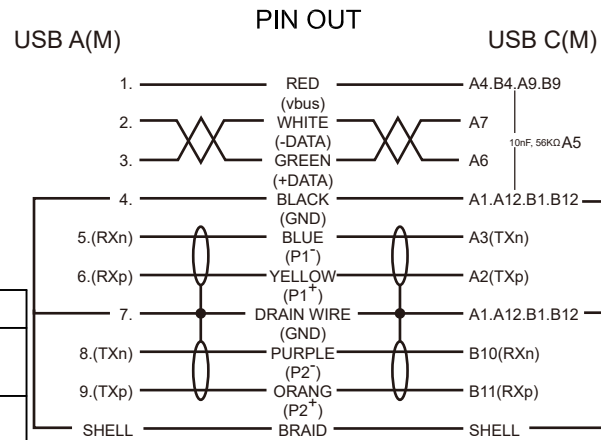

No	MATERIALS LIST:
1.	CABLE: 3 x (2 x 24 AWG)ST + 2 x 22 AWG O.D.:8.8mm COLOR:RED LILAC
2.	CONNECTOR:USB 3.0 A/M, 9P, BLUE INSULATOR SOLDER TYPE, NICKEL PLATED SHELL
3.	CONNECTOR:USB 3.1 TYPE-C, MALE, NICKEL PLATED SHELL
4.	PVC MOLDED HOUSING, BLACK COLOR
5.	SCREW:#4x33 M2
6.	SCREW:#4x34.5 M2

Jargy part no.	Client part no.	Approved	SCALE	UNIT
CBL-HFD3SAB6CSS-xm				mm
Drawing Name		Drawn	Date	REV.
USB 3.1 GEN 1 A to C Cable M/M				1.0

Mobile Computing **JARGY**

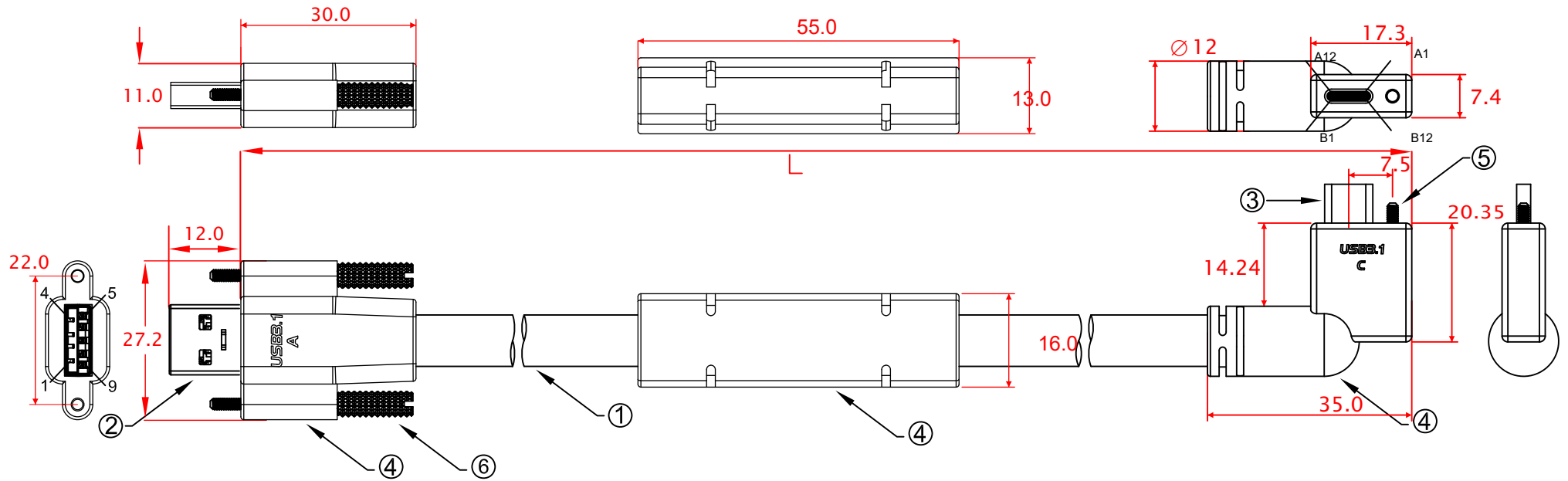

- L:
- | | |
|------------------------|--------------|
| CBL-HFD3SAB6CSH-6mLRA | 6000mm±30mm |
| CBL-HFD3SAB6CSH-7mLRA | 7000mm±30mm |
| CBL-HFD3SAB6CSH-8mLRA | 8000mm±30mm |
| CBL-HFD3SAB6CSH-9mLRA | 9000mm±30mm |
| CBL-HFD3SAB6CSH-10mLRA | 10000mm±30mm |

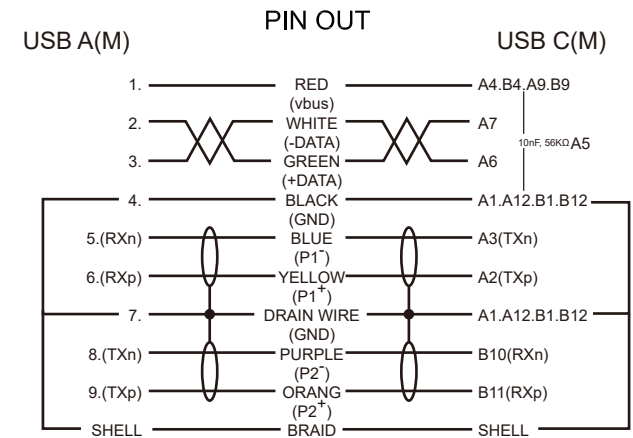

No	MATERIALS LIST:
1.	CABLE: 3 x (2 x 24 AWG)ST + 2 x 22 AWG O.D.:8.8mm COLOR:RED LILAC
2.	CONNECTOR:USB 3.0 A/M, 9P, BLUE INSULATOR SOLDER TYPE, NICKEL PLATED SHELL
3.	CONNECTOR:USB 3.1 TYPE-C, MALE, NICKEL PLATED SHELL
4.	PVC MOLDED HOUSING, BLACK COLOR
5.	SCREW:#4x23.32 M2
6.	SCREW:#4x34.5 M2

Jargy part no.	Client part no.	Approved	SCALE	UNIT
CBL-HFD3SAB6CSH-xmLRA				mm
Drawing Name		Drawn	Date	REV.
USB 3.1 GEN 1 A to C Cable M/M				1.0

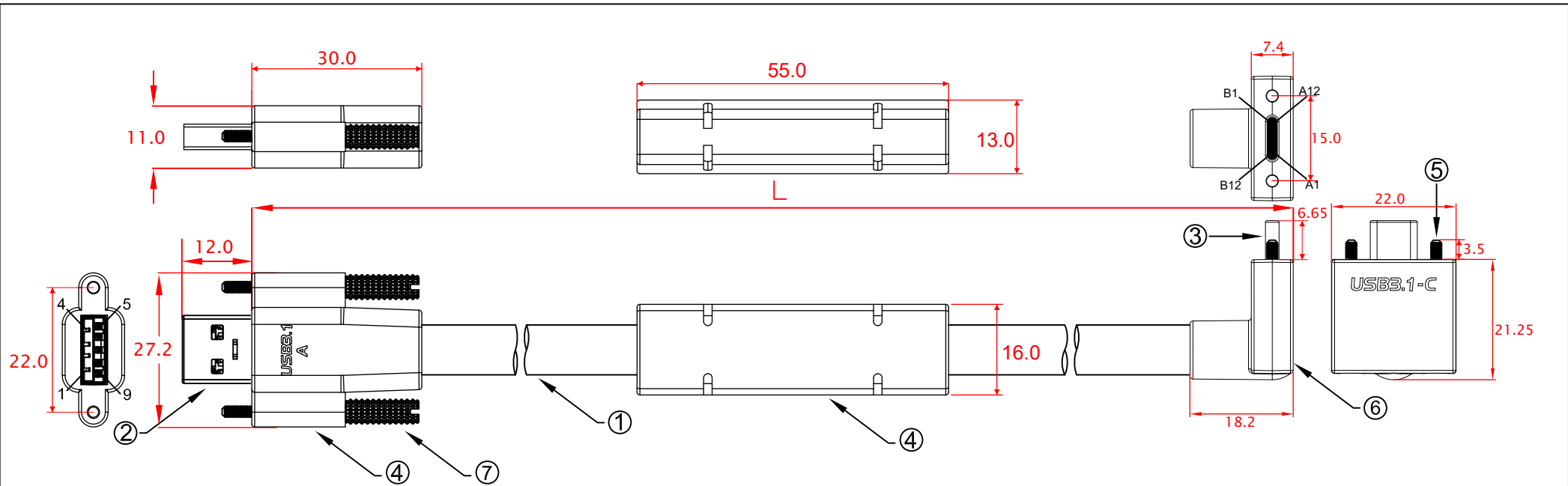

L:

CBL-HFD3SAB6CSH-6mUDA	6000mm±30mm
CBL-HFD3SAB6CSH-7mUDA	7000mm±30mm
CBL-HFD3SAB6CSH-8mUDA	8000mm±30mm
CBL-HFD3SAB6CSH-9mUDA	9000mm±30mm
CBL-HFD3SAB6CSH-10mUDA	10000mm±30mm

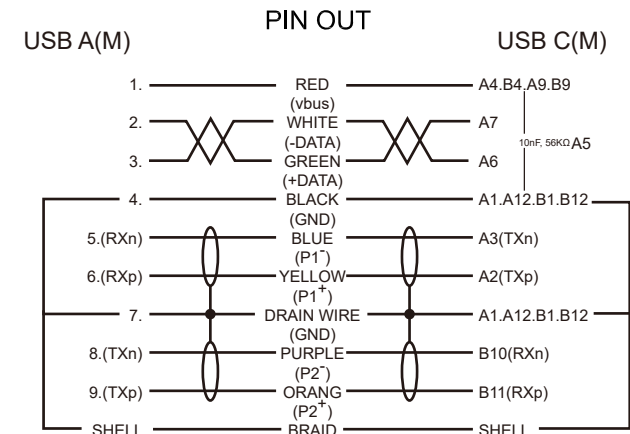

No	MATERIALS LIST:
1.	CABLE: 3 x (2 x 24 AWG)ST + 2 x 22 AWG O.D.:8.8mm COLOR:RED LILAC
2.	CONNECTOR:USB 3.0 A/M, 9P, BLUE INSULATOR SOLDER TYPE, NICKEL PLATED SHELL
3.	CONNECTOR:USB 3.1 TYPE-C, MALE, NICKEL PLATED SHELL
4.	PVC MOLDED HOUSING, BLACK COLOR
5.	SCREW:#4x23.32 M2
6.	ABS ASSEMBLY HOUSING, BLACK COLOR
7.	SCREW:#4x34.5 M2

Jargy part no.	Client part no.	Approved	SCALE	UNIT
CBL-HFD3SAB6CSH-xmUDA				mm
Drawing Name		Drawn	Date	REV.
USB 3.1 GEN 1 A to C Cable M/M				1.0

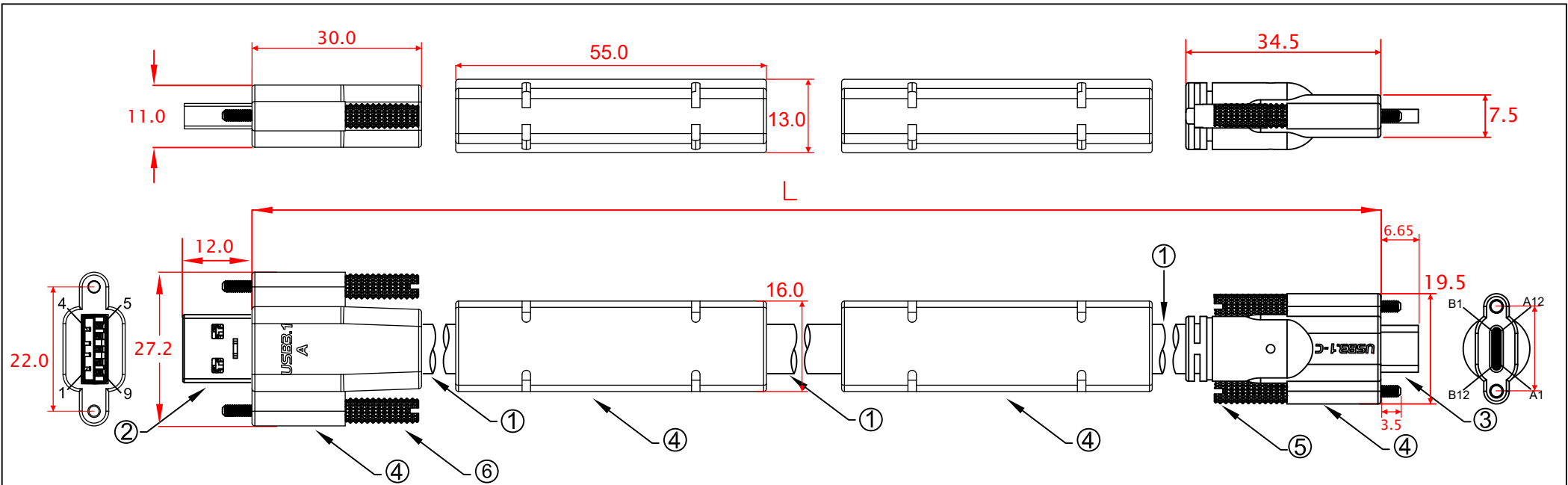

L:

CBL-HFD3SAB6CSS-11m	11000±50mm
CBL-HFD3SAB6CSS-12m	12000±50mm
CBL-HFD3SAB6CSS-13m	13000±50mm
CBL-HFD3SAB6CSS-14m	14000±50mm

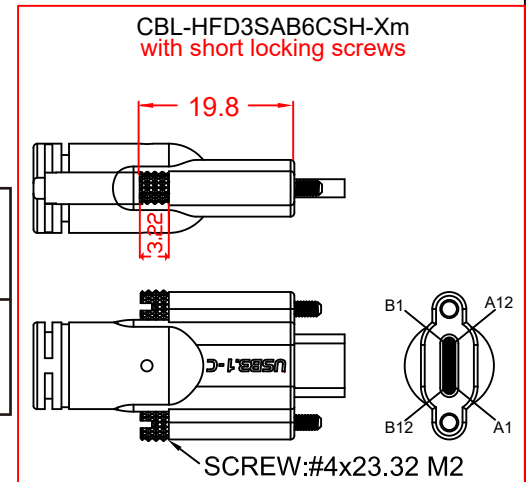
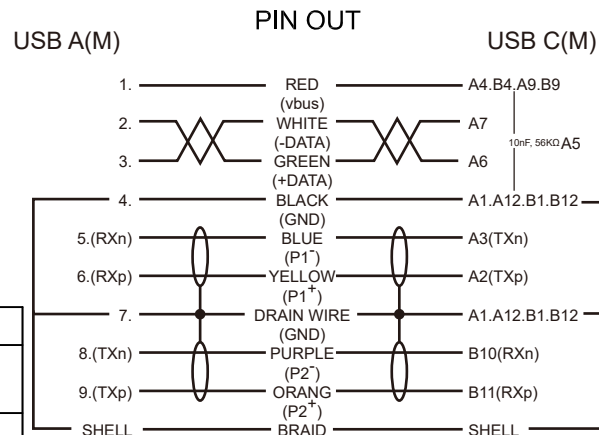

No	MATERIALS LIST:
1.	CABLE: 3 x (2 x 24 AWG)ST + 2 x 22 AWG O.D.:8.8mm COLOR:RED LILAC
2.	CONNECTOR:USB 3.0 A/M, 9P, BLUE INSULATOR SOLDER TYPE, NICKEL PLATED SHELL
3.	CONNECTOR:USB 3.1 TYPE-C, MALE, NICKEL PLATED SHELL
4.	PVC MOLDED HOUSING, BLACK COLOR
5.	SCREW:#4x33 M2
6.	SCREW:#4x34.5 M2

Jargy part no.	Client part no.	Approved	SCALE	UNIT
CBL-HFD3SAB6CSS-xm				mm
Drawing Name		Drawn	Date	REV.
USB 3.1 GEN 1 A to C Cable M/M				1.0

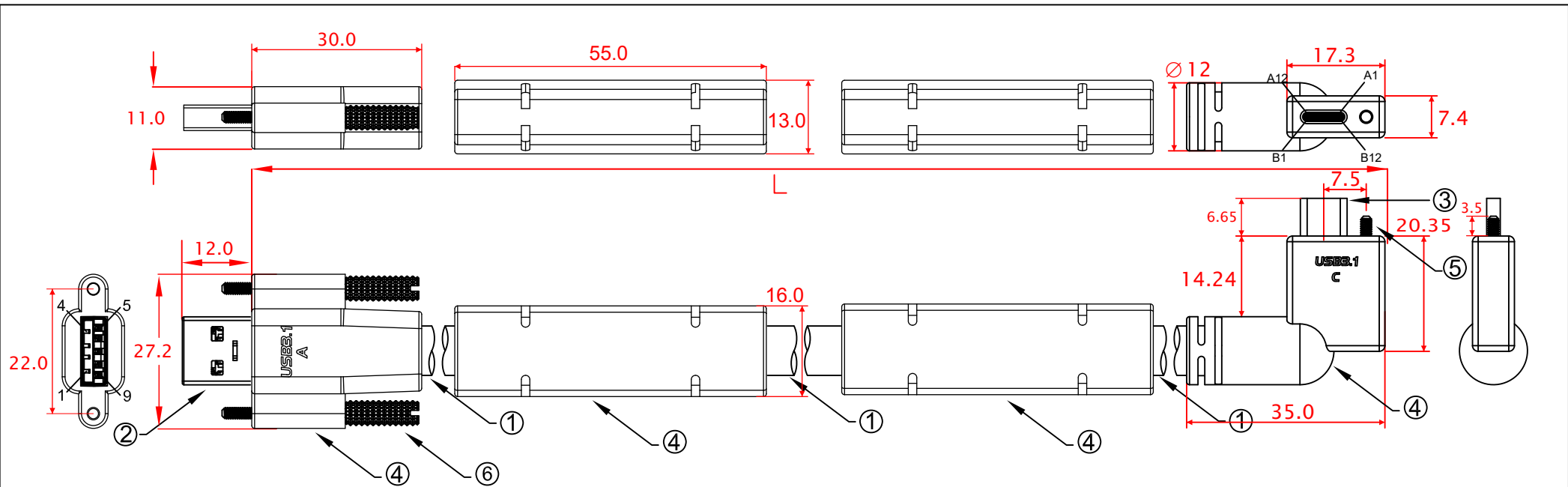

- L:
 CBL-HFD3SAB6CSH-11mLRA 11000±50mm
 CBL-HFD3SAB6CSH-12mLRA 12000±50mm
 CBL-HFD3SAB6CSH-13mLRA 13000±50mm
 CBL-HFD3SAB6CSH-14mLRA 14000±50mm

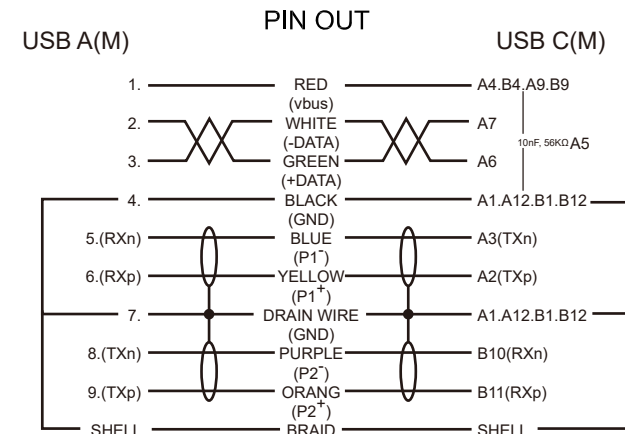

No	MATERIALS LIST:
1.	CABLE: 3 x (2 x 24 AWG)ST + 2 x 22 AWG O.D.:8.8mm COLOR:RED LILAC
2.	CONNECTOR:USB 3.0 A/M, 9P, BLUE INSULATOR SOLDER TYPE, NICKEL PLATED SHELL
3.	CONNECTOR:USB 3.1 TYPE-C, MALE, NICKEL PLATED SHELL
4.	PVC MOLDED HOUSING, BLACK COLOR
5.	SCREW:#4x23.32 M2
6.	SCREW:#4x34.5 M2

Jargy part no.	Client part no.	Approved	SCALE	UNIT
CBL-HFD3SAB6CSH-xmLRA				mm
Drawing Name		Drawn	Date	REV.
USB 3.1 GEN 1 A to C Cable M/M				1.0

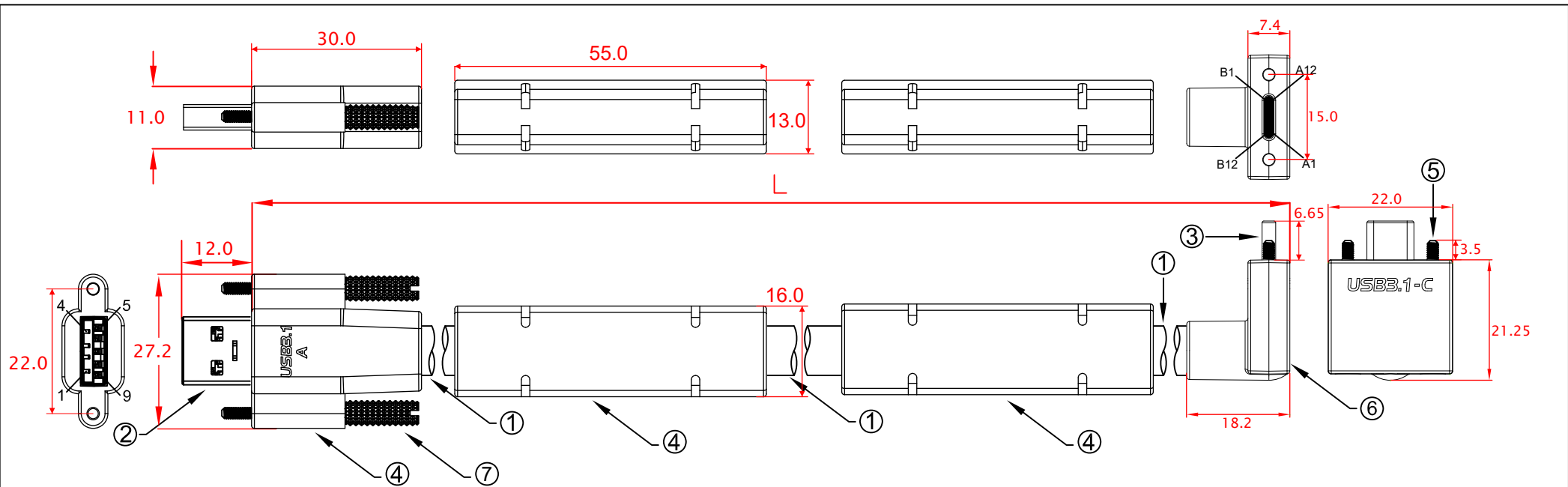

L:
 CBL-HFD3SAB6CSH-11mUDA 11000±50mm
 CBL-HFD3SAB6CSH-12mUDA 12000±50mm
 CBL-HFD3SAB6CSH-13mUDA 13000±50mm
 CBL-HFD3SAB6CSH-14mUDA 14000±50mm

No	MATERIALS LIST:
1.	CABLE: 3 x (2 x 24 AWG)ST + 2 x 22 AWG O.D.:8.8mm COLOR:RED LILAC
2.	CONNECTOR:USB 3.0 A/M, 9P, BLUE INSULATOR SOLDER TYPE, NICKEL PLATED SHELL
3.	CONNECTOR:USB 3.1 TYPE-C, MALE, NICKEL PLATED SHELL
4.	PVC MOLDED HOUSING, BLACK COLOR
5.	SCREW:#4x23.32 M2
6.	ABS ASSEMBLY HOUSING, BLACK COLOR
7.	SCREW:#4x34.5 M2

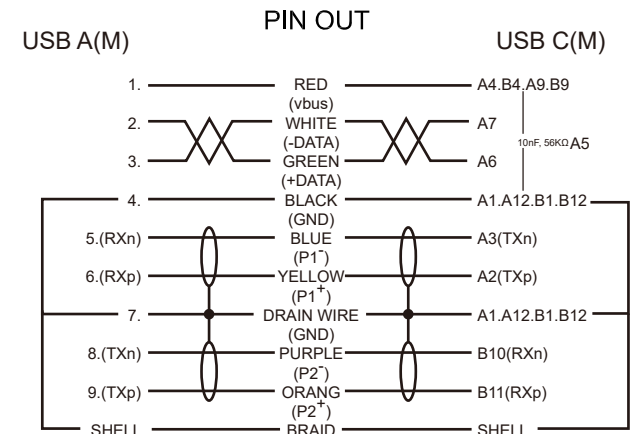

Jargy part no.	Client part no.	Approved	SCALE	UNIT
CBL-HFD3SAB6CSH-xmUDA				mm
Drawing Name		Drawn	Date	REV.
USB 3.1 GEN 1 A to C Cable M/M				1.0

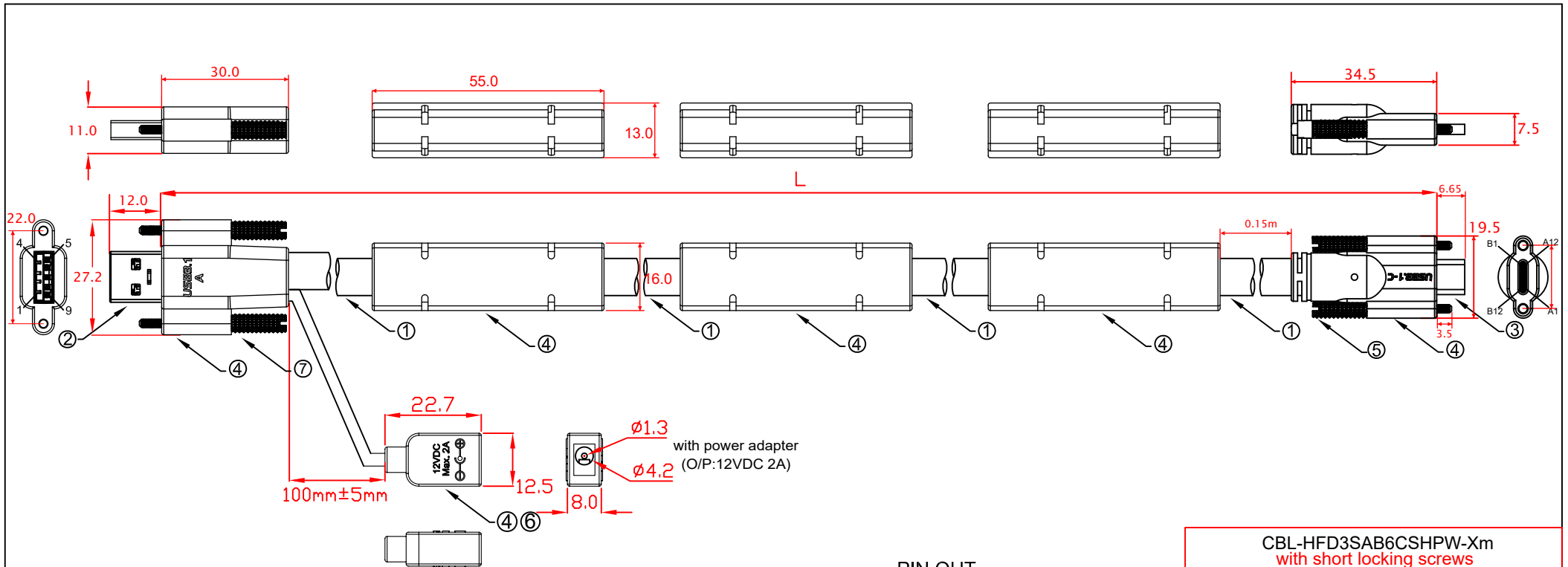

L:
CBL-HFD3SAB6CSSPW-15m 15000mm±50mm

No	MATERIALS LIST:
1.	CABLE: 3 x (2 x 24 AWG)ST + 2 x 22 AWG O.D.:8.8mm COLOR:RED LILAC
2.	CONNECTOR:USB 3.0 A/M, 9P, BLUE INSULATOR SOLDER TYPE, NICKEL PLATED SHELL
3.	CONNECTOR:USB 3.1 TYPE-C, MALE, NICKEL PLATED SHELL
4.	PVC MOLDED HOUSING, BLACK COLOR
5.	SCREW:#4x33 M2
6.	DC JACK 1.3mm 30V 0.3V
7.	SCREW:#4x34.5 M2

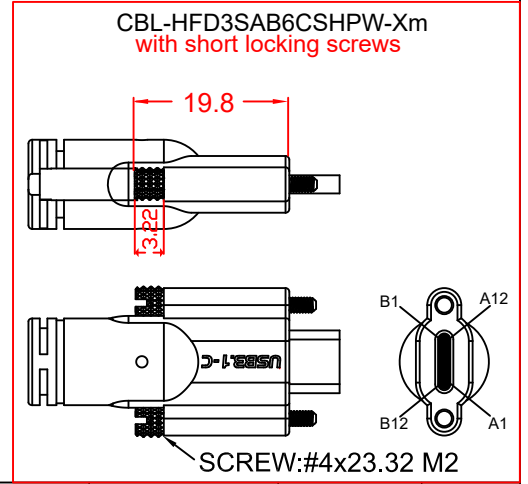
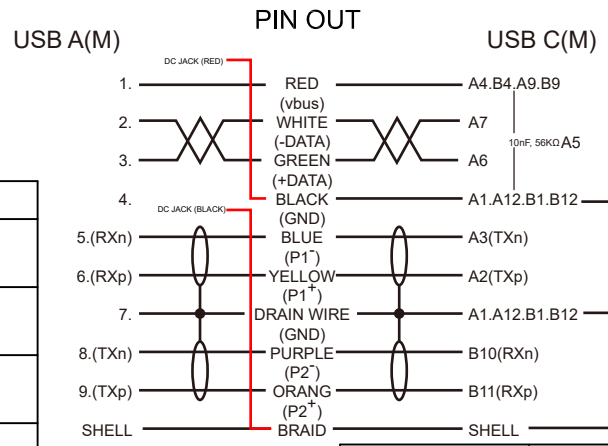

Jargy part no.	Client part no.	Approved	SCALE	UNIT
CBL-HFD3SAB6CSSPW-xm				mm
Drawing Name		Drawn	Date	REV.
USB 3.1 GEN 1 A to C Cable M/M				1.0

Mobile Computing JARGY

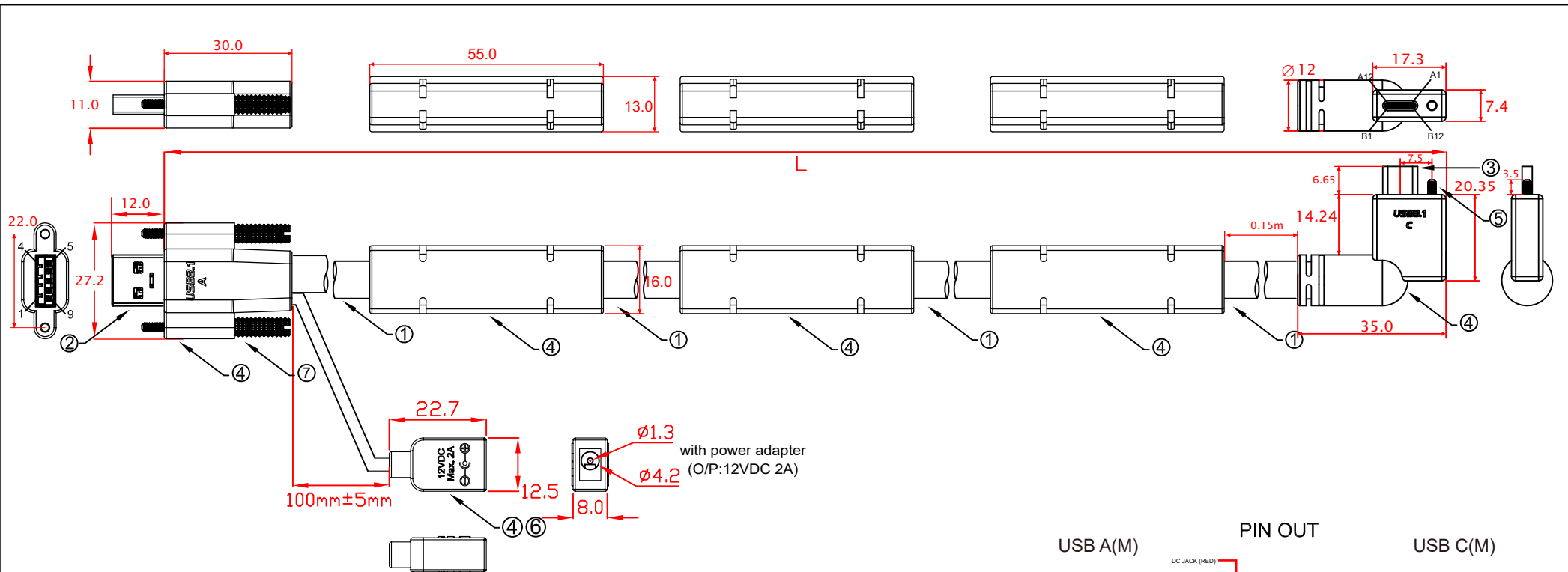

L:
CBL-HFD3SAB6CSHPW-15mLRA 15000mm±50mm

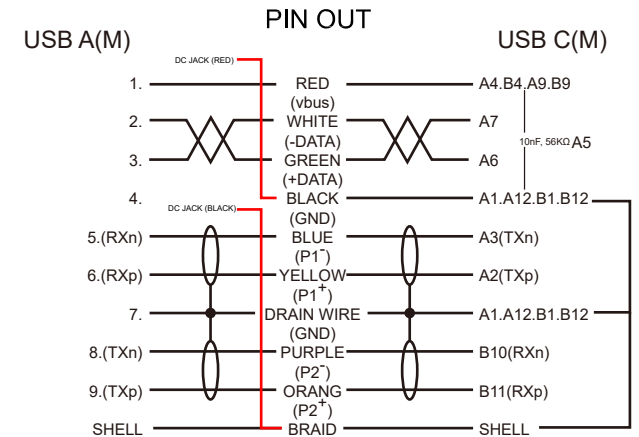

No	MATERIALS LIST:
1.	CABLE: 3 x (2 x 24 AWG)ST + 2 x 22 AWG O.D.:8.8mm COLOR:RED LILAC
2.	CONNECTOR:USB 3.0 A/M, 9P, BLUE INSULATOR SOLDER TYPE, NICKEL PLATED SHELL
3.	CONNECTOR:USB 3.1 TYPE-C, MALE, NICKEL PLATED SHELL
4.	PVC MOLDED HOUSING, BLACK COLOR
5.	SCREW:#4x23.32 M2
6.	DC JACK 1.3mm 30V 0.3V
7.	SCREW:#4x34.5 M2

Jargy part no.	Client part no.	Approved	SCALE	UNIT
CBL-HFD3SAB6CSHPW-xmlRA				mm
Drawing Name		Drawn	Date	REV.
USB 3.1 GEN 1 A to C Cable M/M				1,0

Mobile Computing **JARGY**

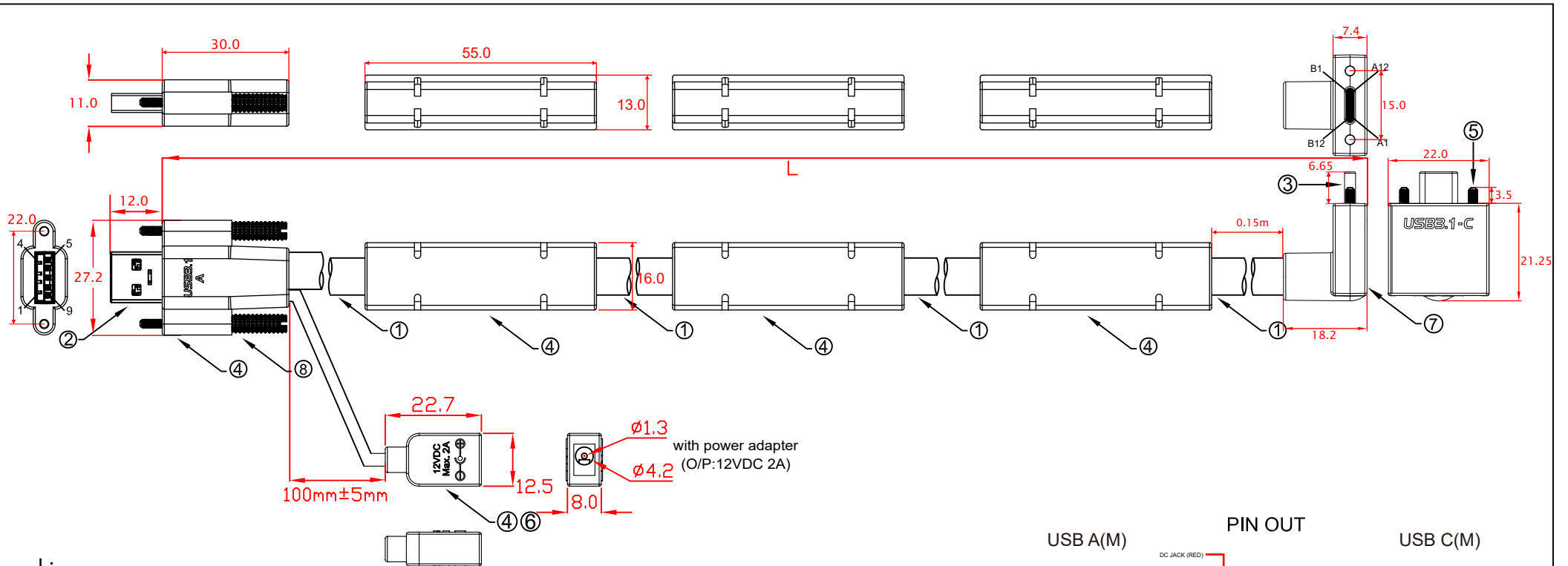

L:
CBL-HFD3SAB6CSHPW-15mUDA15000mm±50mm

No	MATERIALS LIST:
1.	CABLE: 3 x (2 x 24 AWG)ST + 2 x 22 AWG O.D.:8.8mm COLOR:RED LILAC
2.	CONNECTOR:USB 3.0 A/M, 9P, BLUE INSULATOR SOLDER TYPE, NICKEL PLATED SHELL
3.	CONNECTOR:USB 3.1 TYPE-C, MALE, NICKEL PLATED SHELL
4.	PVC MOLDED HOUSING, BLACK COLOR
5.	SCREW:#4x23.32 M2
6.	DC JACK 1.3mm 30V 0.3V
7.	ABS ASSEMBLY HOUSING, BLACK COLOR
8.	SCREW:#4x34.5 M2

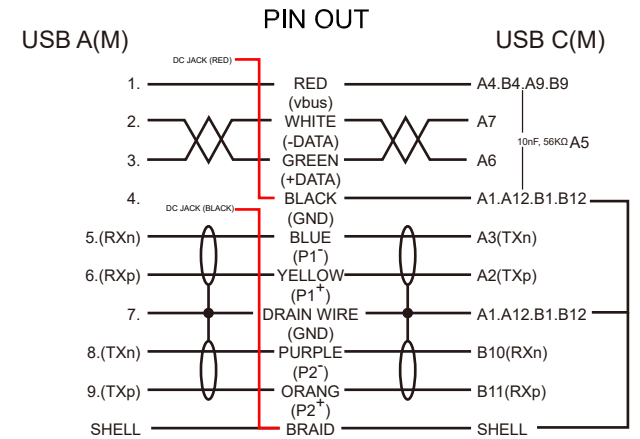

Jargy part no.	Client part no.	Approved	SCALE	UNIT
CBL-HFD3SAB6CSHPW-xmUDA				mm
Drawing Name		Drawn	Date	REV.
USB 3.1 GEN 1 A to C Cable M/M				1,0

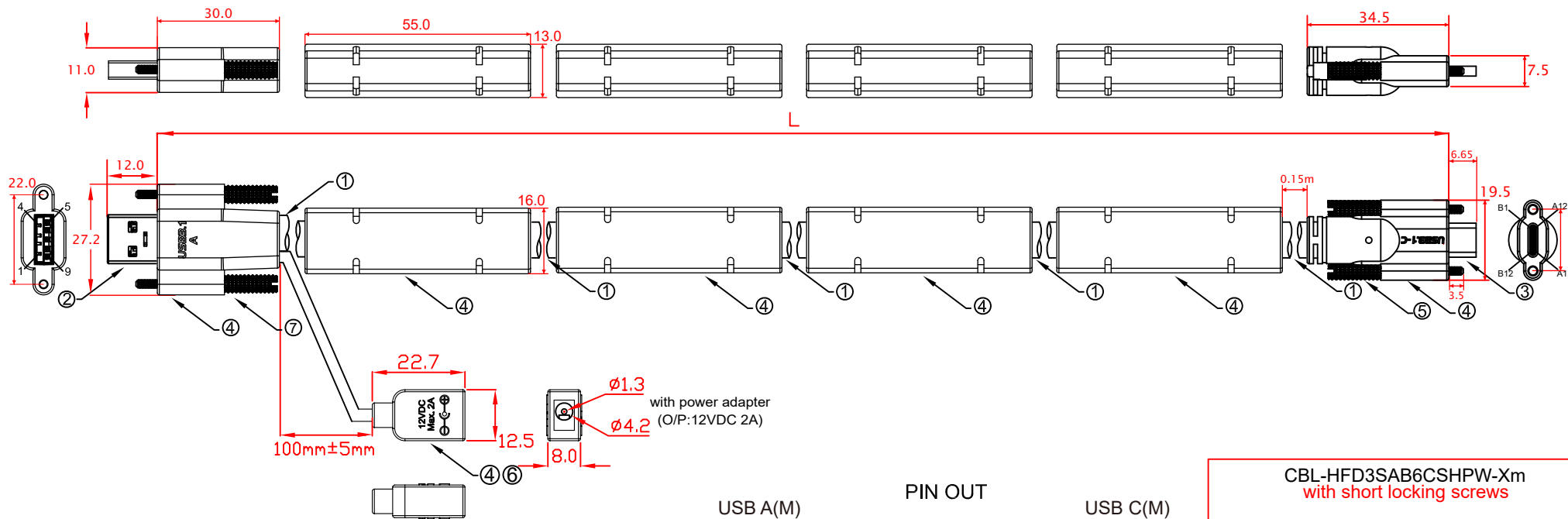

L:
CBL-HFD3SAB6CSPW-20m 20000±50mm

No	MATERIALS LIST:
1.	CABLE: 3 x (2 x 24 AWG)ST + 2 x 22 AWG O.D.:8.8mm COLOR:RED LILAC
2.	CONNECTOR:USB 3.0 A/M, 9P, BLUE INSULATOR SOLDER TYPE, NICKEL PLATED SHELL
3.	CONNECTOR:USB 3.1 TYPE-C, MALE, NICKEL PLATED SHELL
4.	PVC MOLDED HOUSING, BLACK COLOR
5.	SCREW:#4x33 M2
6.	DC JACK 1.3mm 30V 0.3V
7.	SCREW:#4x34.5 M2

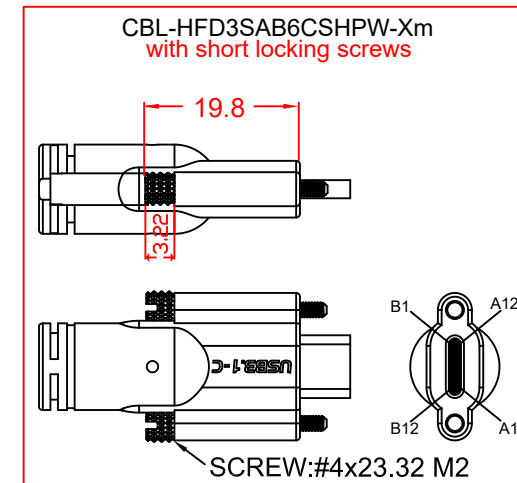
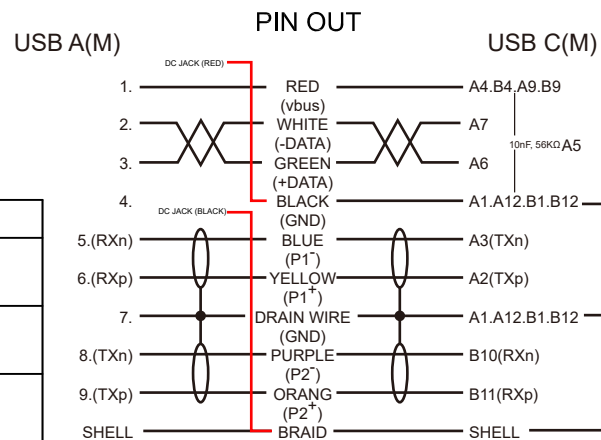

Jargy part no.	Client part no.	Approved	SCALE	UNIT
CBL-HFD3SAB6CSPW-xm				mm
Drawing Name		Drawn	Date	REV.
USB 3.1 GEN 1 A to C Cable M/M				1.0



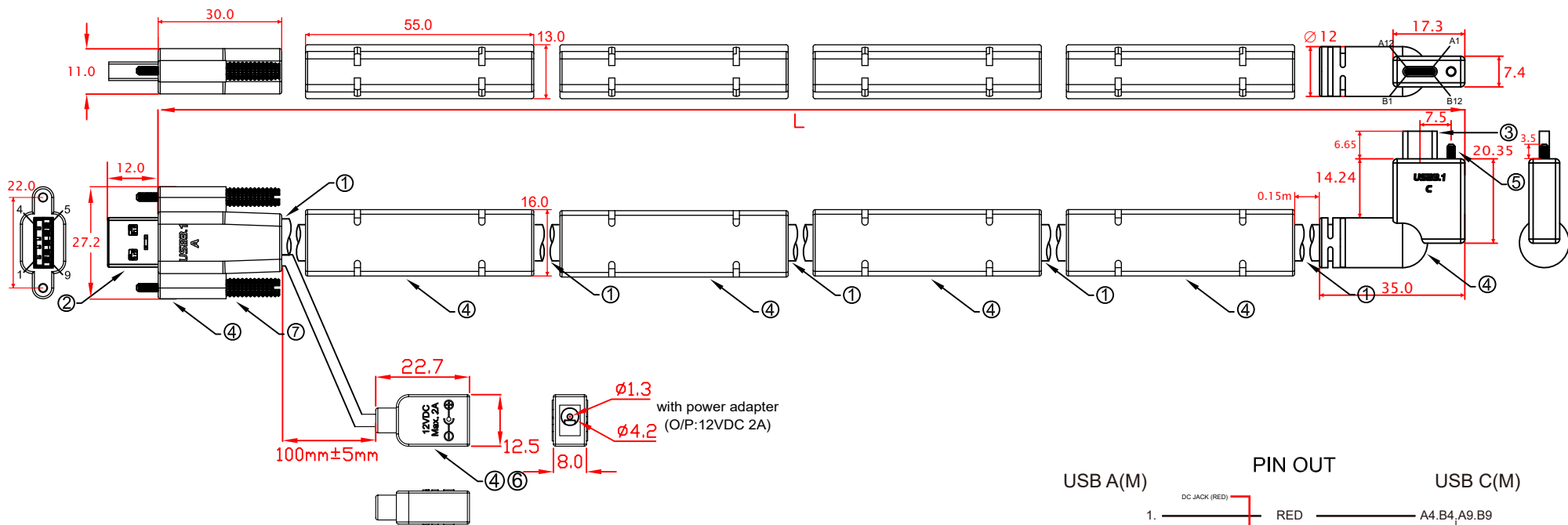

L:
CBL-HFD3SAB6CSHPW-20mLRA 20000±50mm

No	MATERIALS LIST:
1.	CABLE: 3 x (2 x 24 AWG)ST + 2 x 22 AWG O.D.:8.8mm COLOR:RED LILAC
2.	CONNECTOR:USB 3.0 A/M, 9P, BLUE INSULATOR SOLDER TYPE, NICKEL PLATED SHELL
3.	CONNECTOR:USB 3.1 TYPE-C, MALE, NICKEL PLATED SHELL
4.	PVC MOLDED HOUSING, BLACK COLOR
5.	SCREW:#4x23.32 M2
6.	DC JACK 1.3mm 30V 0.3V
7.	SCREW:#4x34.5 M2

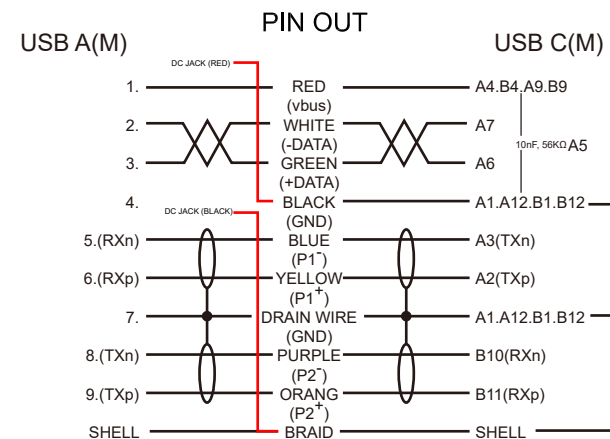

Jargy part no.	Client part no.	Approved	SCALE	UNIT
CBL-HFD3SAB6CSHPW-xmLRA				mm
Drawing Name		Drawn	Date	REV.
USB 3.1 GEN 1 A to C Cable M/M				1.0

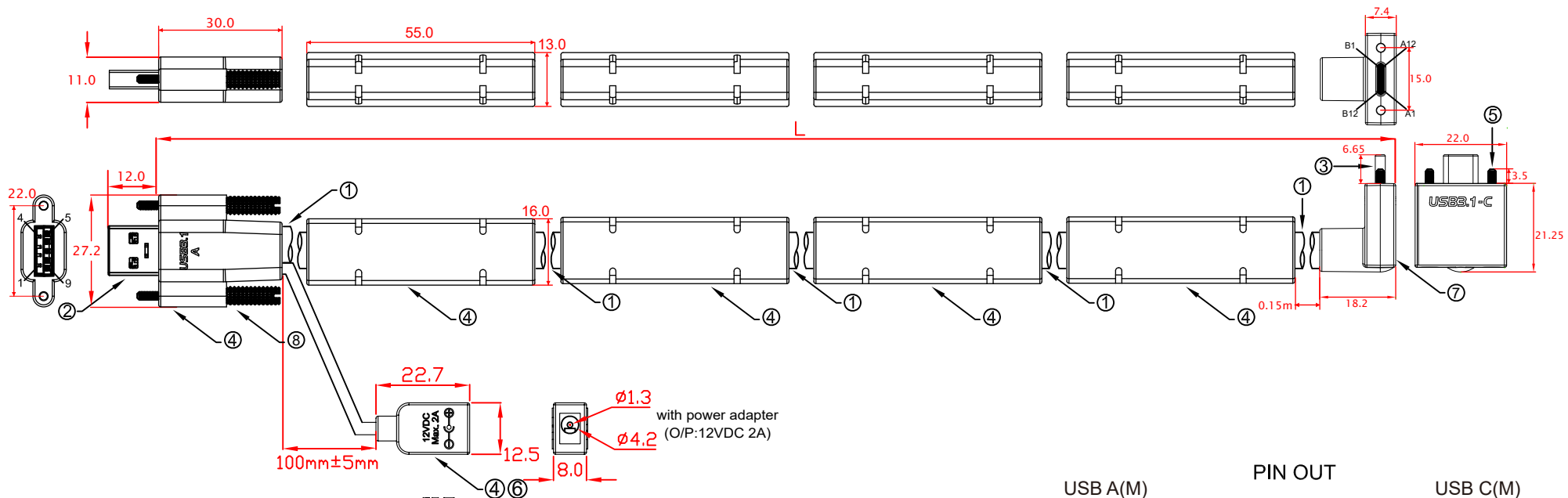

L:
CBL-HFD3SAB6CSHPW-20mUDA 20000±50mm

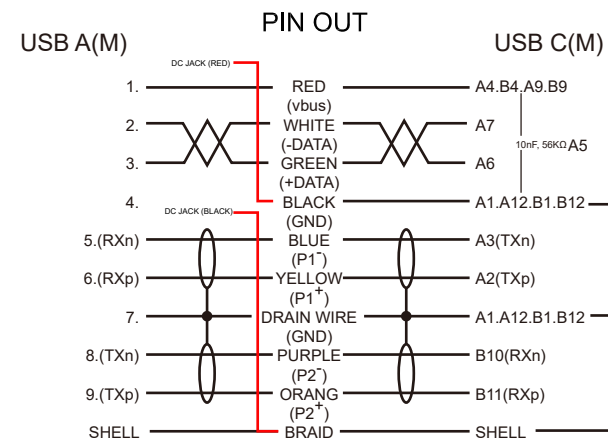

No	MATERIALS LIST:
1.	CABLE: 3 x (2 x 24 AWG)ST + 2 x 22 AWG O.D.:8.8mm COLOR:RED LILAC
2.	CONNECTOR:USB 3.0 A/M, 9P, BLUE INSULATOR SOLDER TYPE, NICKEL PLATED SHELL
3.	CONNECTOR:USB 3.1 TYPE-C, MALE, NICKEL PLATED SHELL
4.	PVC MOLDED HOUSING, BLACK COLOR
5.	SCREW:#4x23.32 M2
6.	DC JACK 1.3mm 30V 0.3V
7.	ABS ASSEMBLY HOUSING, BLACK COLOR
8.	SCREW:#4x34.5 M2

Jargy part no.	Client part no.	Approved	SCALE	UNIT
CBL-HFD3SAB6CSHPW-xmUDA				mm
Drawing Name		Drawn	Date	REV.
USB 3.1 GEN 1 A to C Cable M/M				1.0